

Hydroflex

Waterproofing Products

www.arfen.com - www.arfen.eu

effective and permanent waterproofing solutions

CONTENTS

PVC Waterstop Tapes

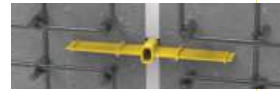

Page **01**

Swellable Tapes



Page **13**

TPE Expansion Joint Tapes



Page **16**

Chamfer Tapes



Page **18**

Sealants



Page **19**

Aluminium Insulation Pressure Profile



Page **20**

Butyl Tapes



Page **22**

Hydroflex waterproofing products are used in waterproofing applications in the construction industry. PVC waterstop tapes providing critical solutions in customized details, TPE dilatation tapes, water-swellable acrylic and TPE gaskets, polyurethane sealant, epoxy adhesive and insulation pressure profiles.



HYDROFLEX PVC Waterstops

Hydroflex PVC-based waterstop tapes are produced in accordance with TS 3078-1 and TS 3078-2 standards, with the desired mechanical and chemical properties in the sections and dimensions specified.

Hydroflex water barrier tapes are used along concrete joints (construction joints and/or expansion joints) to prevent water from passing from one side to the other, where there is water pressure. This function is based on the principle of extending the path of water to achieve the desired effect.

APPLICATION AREAS

- Dams
- Irrigation Channels
- Water Reservoirs
- Swimming Pools
- Metro Stations
- Retaining Walls
- Raft Foundations
- Joint Locations of Shear Walls
- Reinforced Concrete Structures Below Water Level

PVC Waterstops (gaskets) must maintain their sealing performance under the calculated water pressure in the design, preventing water from entering or exiting the structure through the joints.



TS3078-2 Mechanical Properties

| Analysis | Standard | Basic requirement |
|---|-----------|---------------------------------------|
| Appearance inspection | TS 3078-2 | No gaps, cracks, shrinkage, etc. |
| Size inspection | TS 3078-2 | Dimensions must comply with TS 3078-1 |
| Shore A hardness | TS 3078-2 | 70 ± 5 |
| Tensile strength | TS 3078-2 | ≥ 10 MPa |
| Elongation rate at break | TS 3078-2 | ≥ %275 |
| Tear resistance | TS 3078-2 | ≥ 12 kN/m |
| Low temperature behavior: Elongation at break at -20 °C | TS 3078-2 | ≥ %200 |
| Behavior: | | |
| a) After soaking in slaked lime milk | | |
| b) Behavior in the face of heat | | |
| c) Behavior after aging | | |
| Percentage change in the average value compared to the initial value: | TS 3078-2 | |
| Tensile strength | | ≤ %20 |
| Elongation rate at break | | ≤ %20 |
| Modulus of elasticity | | ≤ %50 |
| Joint strength | | Rupture outside the weld zone or |
| Short-term junction factor (f _j) | TS 3078-2 | ≥ 0.6 |
| Fire reaction class according to TS EN 13501-1+A1 | TS 3078-2 | Class E must be |
| Residue fraction by mass | TS 3078-2 | < %5.0 |

Economic Formula Mechanical Properties

| Analysis | Unit | Result |
|---------------------------------------|-------------------|-------------------------------|
| Tensile strength (σ ₀) | MPa | 12.25 |
| Elongation at break (ε ₀) | % | 235 |
| Hardness (H ₀) | Shore A | 75 ± 5 |
| Unit volume mass | g/cm ³ | 1.40 ± 0.04 |
| Ash content by mass | % | 15 |
| After aging | | |
| • Tensile strength | MPa | Maximum 0.80 × σ ₀ |
| • Elongation at break | % | Minimum 0.80 × ε ₀ |
| • Hardness | Shore A | H ₀ ± 5 |

HYDROFLEX PVC Waterstops

The thickness of the structural element must be at least the width of the waterstop band or more.
(300 mm concrete thickness is sufficient for 320 mm waterstop tapes.)
(250 mm concrete thickness is sufficient for 240 mm waterstop tapes.)

The embedding depth (G) of the waterstop gaskets in the concrete should be at least as much as the concrete cover thickness (T). **(Figure 1)**

The distance between the outer edges of the waterstop tape and the nearest reinforcement around it should be at least 20 mm. **(Figure 2)**

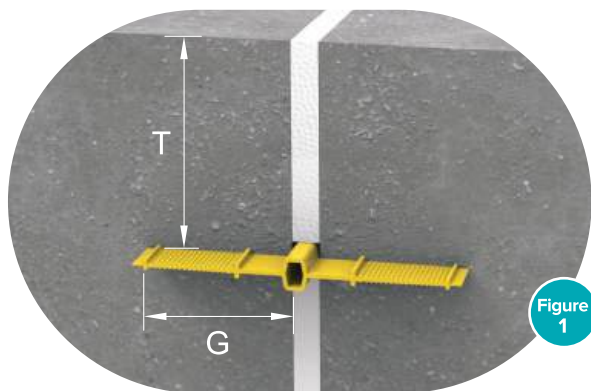

Figure 1

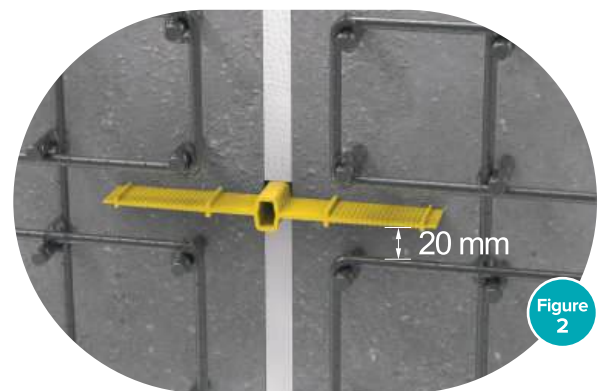

Figure 2

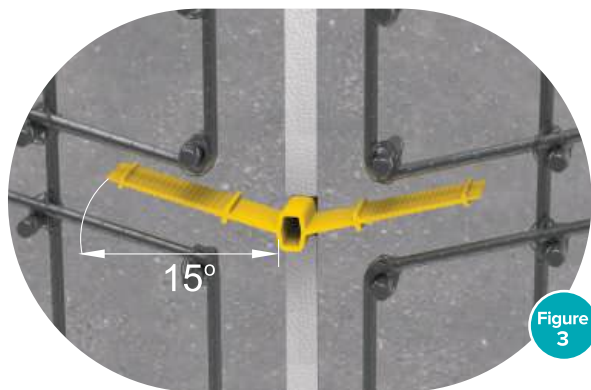

Figure 3



Figure 4

If concrete is poured on a part of the waterstop gasket during each construction phase, the exposed part of the waterstop tape should be at least 1 m.

Gaskets (floor or ceiling, etc.) placed in the concrete in horizontal and slightly inclined structural elements should be placed in a slight V shape during concrete pouring. **(Figure 3)**

Waterstop gaskets placed outside the concrete are placed on the side where the water is. These gaskets must be properly protected at all times against mechanical damage to the shear walls.

While the waterstop gaskets placed outside the concrete can carry a load of up to 0.2 bar against unpressurized water on the unnotched side, there must be at least two notched anchor threads on both sides of these gaskets. **(Figure 4)**

PVC Waterstop Accessories

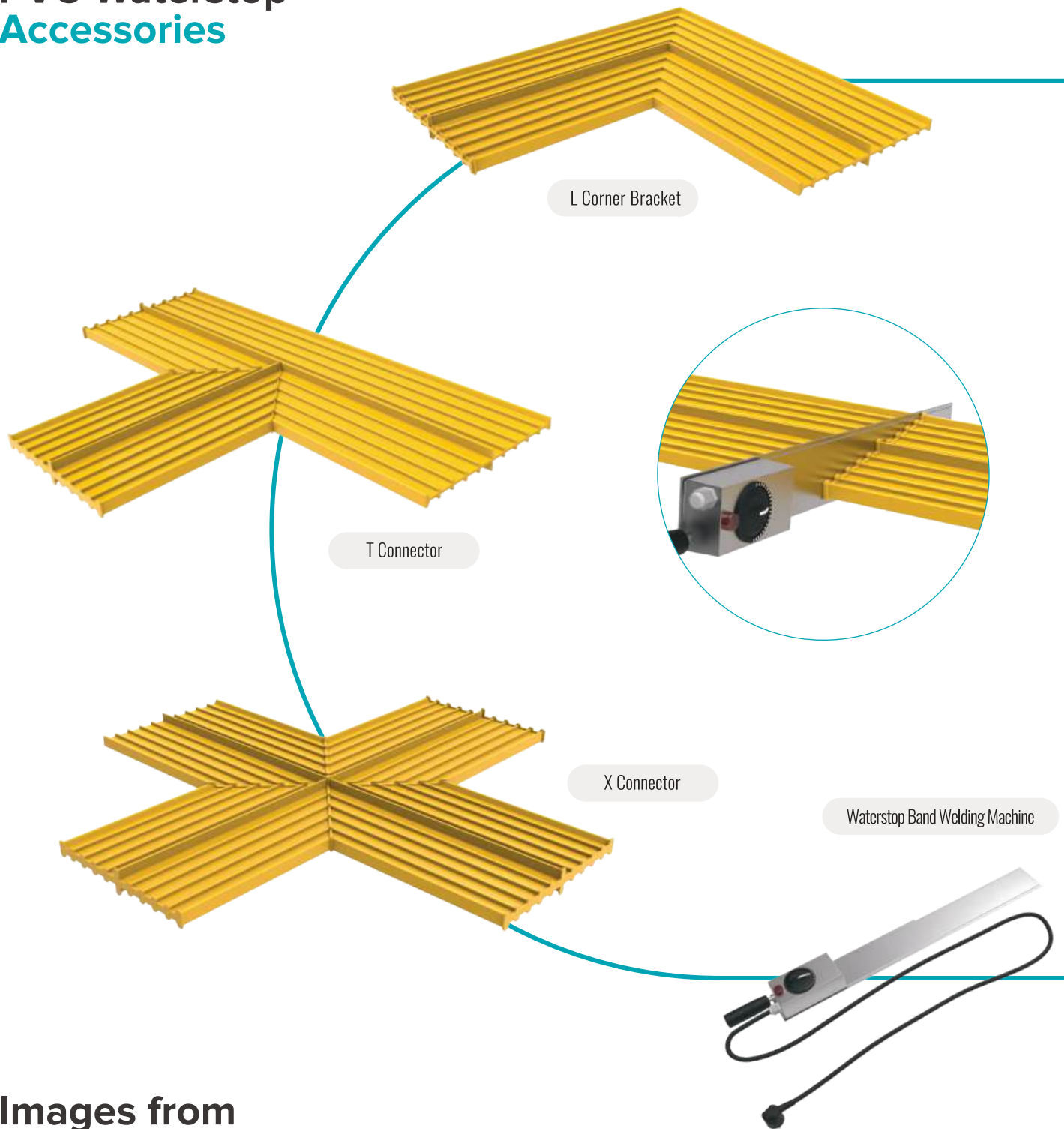

Images from our laboratory

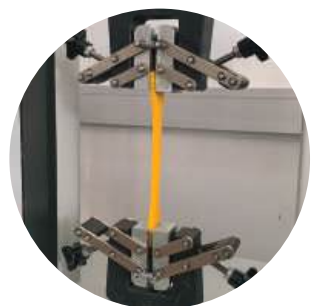

Tensile, rupture tests, aging tests, density and hardness measurements are made continuously in our laboratory.



HYDROFLEX TYPE A WATERSTOP TAPES

High Sealing Performance

Type A waterstop tapes are placed within concrete structural elements for usage in non-expansive, partially contracting, and fully contracting joints. These tapes are used in radial-radial, radial-curtain, and curtain-curtain joints. They are produced in five different widths. (150, 200, 240, 320, 500)

APPLICATION AREAS

- Dams.
- Irrigation channels.
- Water reservoirs.
- Swimming pools.
- Metro stations.
- Retaining walls.
- Raft foundations.
- Curtain walls and their joint locations.
- Reinforced Concrete Structures Below Water Level

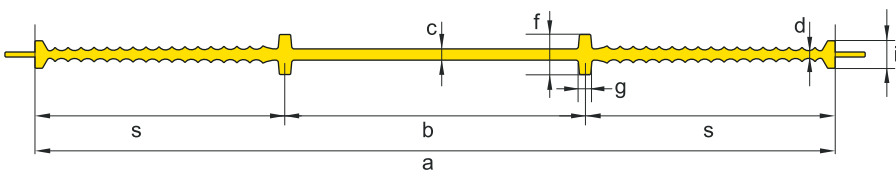

Type A Waterstop Tape Seal, Nominal Dimensions (mm)

| Product Code | a Minimum | b Minimum | c Minimum | d Minimum | f Minimum | g Minimum | i Minimum | s Minimum |
|--------------|--------------|--------------|--------------|--------------|--------------|--------------|--------------|--------------|
| A 15-4 | 150 | 55 | 3.5 | 2.5 | 15 ≥ 3 c | ≥ c | 11 ≥ d+6 | 47.5 |
| A 20-4 | 200 | 70 | 3.5 | 2.5 | | | | 57.5 |
| A 24-4 | 240 | 80 | 3.5 | 2.5 | | | | 62.5 |
| A 32-5 | 320 | 100 | 4.5 | 3.0 | | | | 75 |
| A 50-6 | 500 | 150 | 6.0 | 3.5 | 18 ≥ 3 c | | | 100 |

TS 3078-1 Table 2

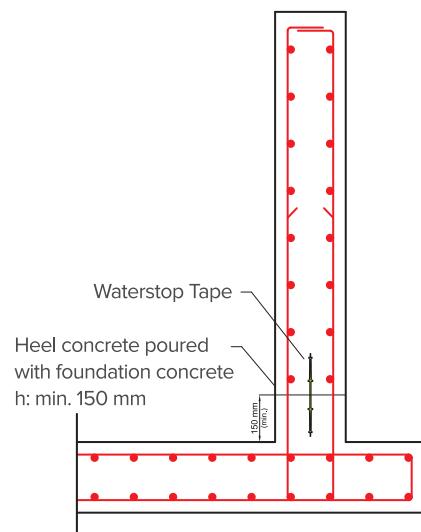



HYDROFLEX TYPE AA WATERSTOP TAPES

Professional Solution for
Partial Contraction and
Full Contraction Joints

It is a type of waterstop tape with vertical dovetail profiles and nails designed to prevent the tape from being pulled out of the concrete and to enhance water resistance. It is used in joints without expansion gaps where the base is flat and there is no midsection expansion gap. This tape is placed on the outer surface of the concrete. It is used in radial-radial and curtain-curtain joints in partial and full contraction joints. They are produced in five different widths. (150, 200, 240, 320, 500)

APPLICATION AREAS

- Dams.
- Irrigation channels.
- Water reservoirs.
- Swimming pools.
- Metro stations.
- Retaining walls.
- Raft foundations.
- Curtain walls and their joint locations.
- Reinforced Concrete Structures Below Water Level

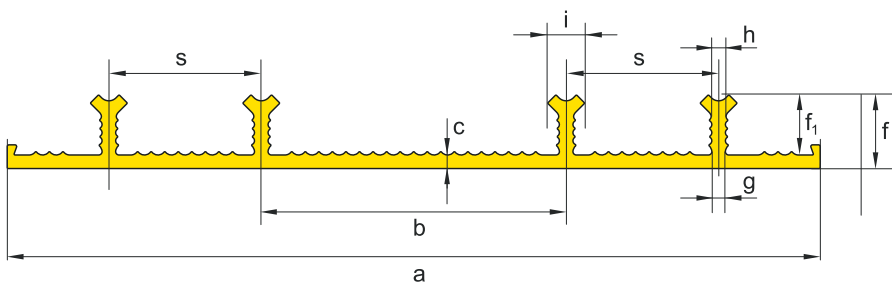

Type AA Waterstop Tape Seal, Nominal Dimensions (mm)

| Product Code | a Minimum | b Minimum | c Minimum | N Minimum | e Minimum | f Minimum | f1 Minimum | g Minimum | h Minimum | i Minimum |
|--------------|--------------|--------------|--------------|--------------|--------------|--------------|---------------|---------------------|--------------|--------------|
| AA 15-4 | 150 | 55 | 4 | 4 | 45 | 20 | 16 | 4 ≥ c ≥ 0.2 f | 4 | 11 ≥ h+6 |
| AA 20-4 | 200 | 70 | | 4 | | 20 | 16 | | | |
| AA 24-4 | 240 | 80 | | 4 | | 20 | 16 | | | |
| AA 32-4 | 320 | 100 | | 6 | | 25 | 21 | | | |
| AA 50-4 | 500 | 150 | | 8 | | 25 | 21 | | | |

TS 3078-1 Table 4



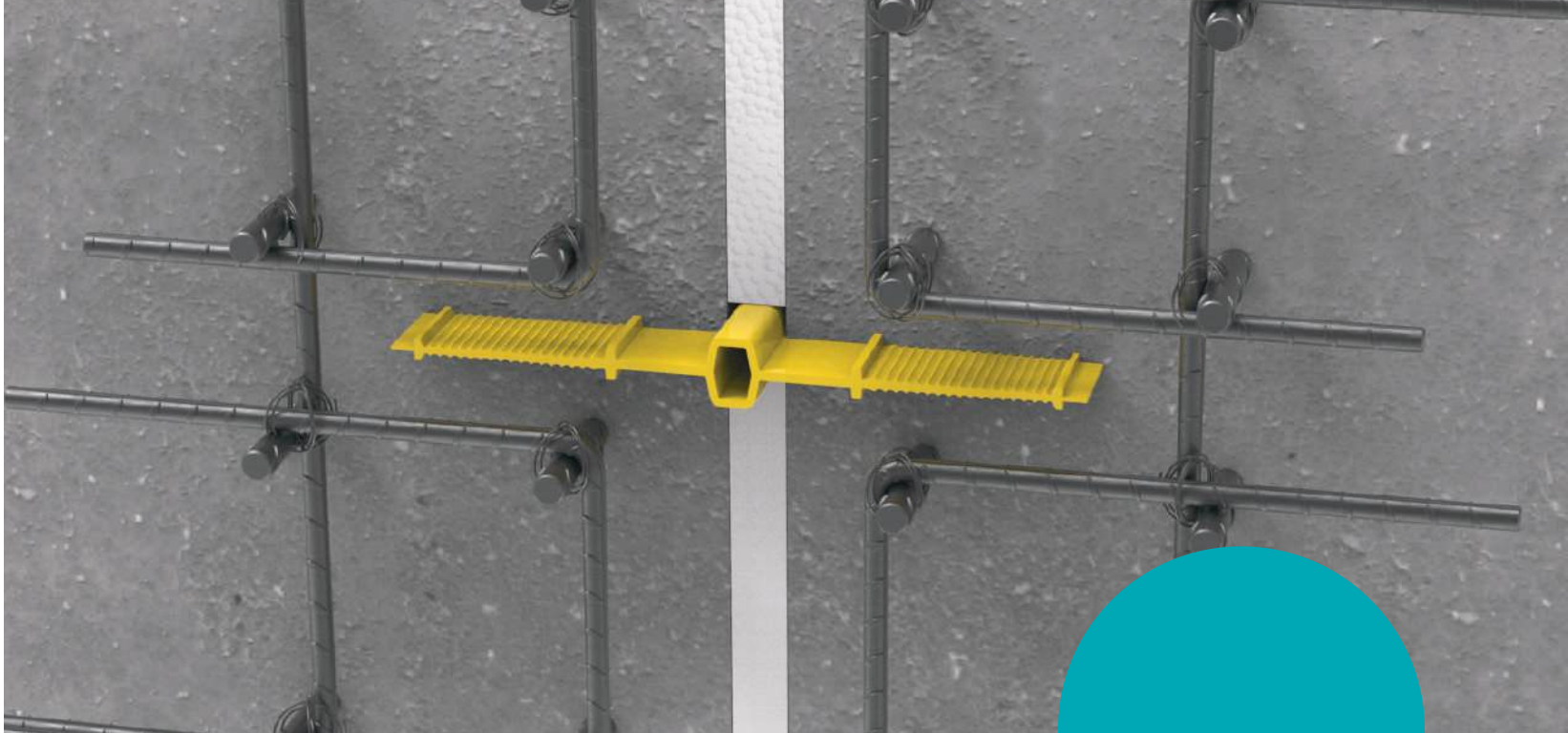

HYDROFLEX TYPE D WATERSTOP TAPES

PVC Based
Excellent Insulation

Expansion type waterstop tape is embedded within concrete and is used in expansion joints, particularly in radial-radial and curtain-curtain joints, positioned near the center of the section. They are produced in five different widths. (150, 200, 240, 320, 500)

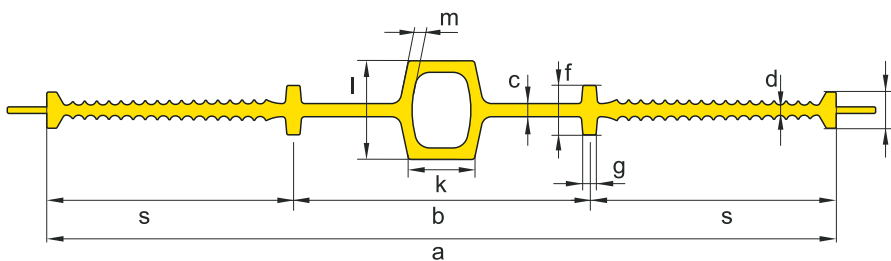
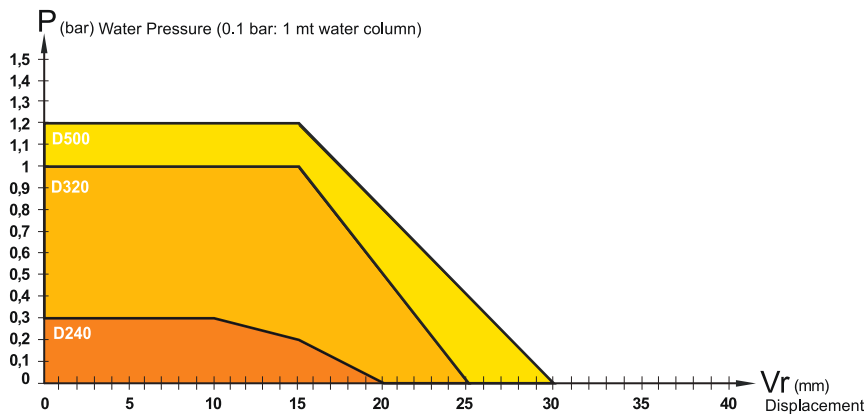

Type D Waterstop Tape Seal, Nominal Dimensions (mm)

| Product Code | a | b | c | d | f | g | l | k | l | m | s |
|--------------|---------|---------|---------|---------|------------|---------|-------------|---------|------------|---------|---------|
| | Minimum | Minimum | Minimum | Minimum | Minimum | Minimum | Minimum | Minimum | Minimum | Minimum | Minimum |
| D 15-4 | 150 | 55 | 3.5 | 2.5 | 15 ≥ 3c | ≥ c | 11 ≥ d+6 | 20 | 30 | 3.5 | 47.5 |
| D 20-4 | 200 | 70 | 3.5 | 2.5 | | | | | 30 | 3.5 | 57.5 |
| D 24-4 | 240 | 80 | 4 | 3 | | | | | 30 | 3.5 | 62.5 |
| D 32-5 | 320 | 100 | 5 | 3.5 | | | | | 35 | 4 | 75 |
| D 50-6 | 500 | 150 | 6 | 4.5 | | | | | 18 ≥ 3c | 45 | 4.5 |





DA type waterstop tapes are designed to be placed on the outer surface of concrete, particularly in joints with expansion gaps, where the base is flat and there is an expansion gap in the middle. These tapes have nails in vertical orientation and striped surfaces on both sides of the tape to extend the path of water and enhance water resistance. They are produced in five different widths. (150, 200, 240, 320, 500)

HYDROFLEX TYPE DA WATERSTOP TAPES

Professional Solution for
Partial Contraction and
Full Contraction Joints

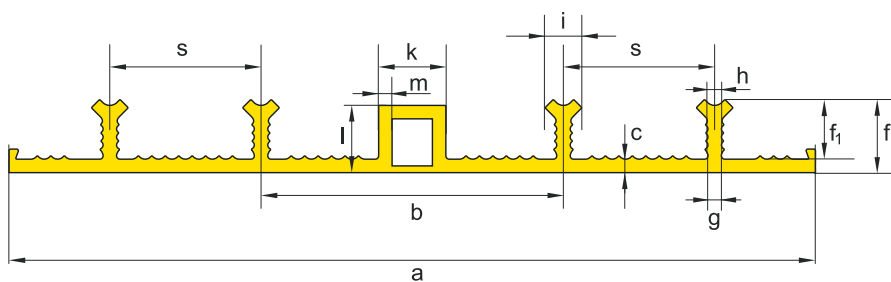
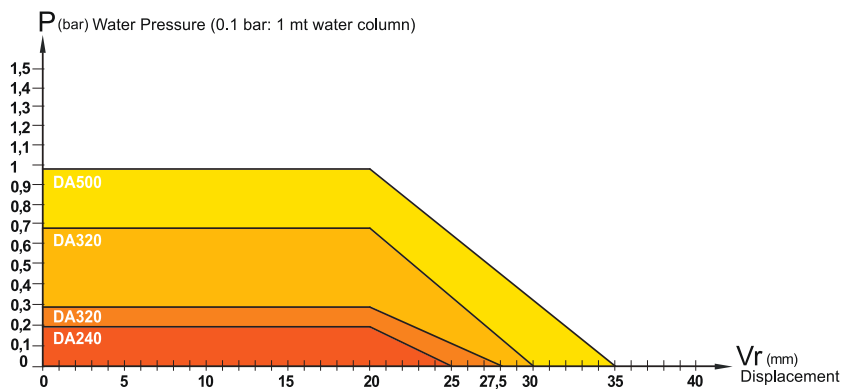

Type DA Waterstop Tape Seal, Nominal Dimensions (mm)

| Product Code | a Minimum | b Minimum | c Minimum | N Minimum | e Minimum | f Minimum | f ₁ Minimum | g Minimum | h Minimum | i Minimum | k Minimum | l Minimum | m Minimum |
|--------------|-----------|-----------|-----------|-----------|-----------|-----------|------------------------|--------------------|-----------|-------------|-----------|-----------|-----------|
| DA 15-4 | 150 | 60 | 4 | 4 | 45 | 20 | 16 | 4 ≥ c ≥ 0.2f | 4 | 11 ≥ h+6 | 20 | 20 | 4 |
| DA 20-4 | 200 | 80 | | 4 | | 20 | 16 | | | | | | |
| DA 24-4 | 240 | 90 | | 4 | | 20 | 16 | | | | | | |
| DA 32-4 | 320 | 100 | | 6 | | 25 | 21 | | | | | | |
| DA 50-4 | 500 | 120 | | 8 | | 25 | 21 | | | | | | |

TS 3078-1 Table 3



HYDROFLEX TYPE FA WATERSTOP TAPES

Type U
PVC Waterstop Tape

U type PVC waterstop tapes are used when the cross-section is in a U shape and when the installation of iron reinforcement on the outer side of the concrete structure is not suitable for other types. These tapes are utilized in situations where other types are not suitable for mounting due to the presence of U-shaped reinforcement. They exhibit a somewhat lower hydrostatic pressure resistance compared to other types.

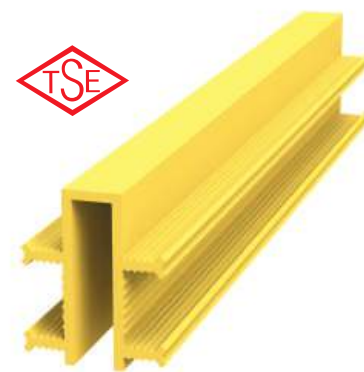
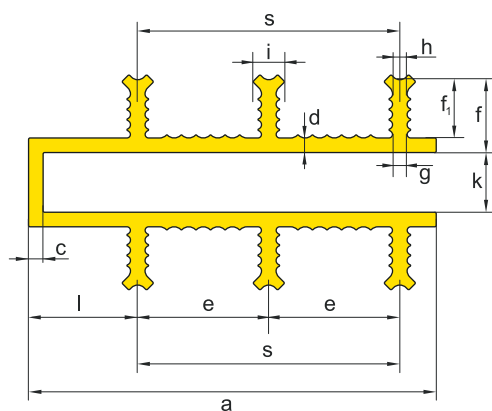
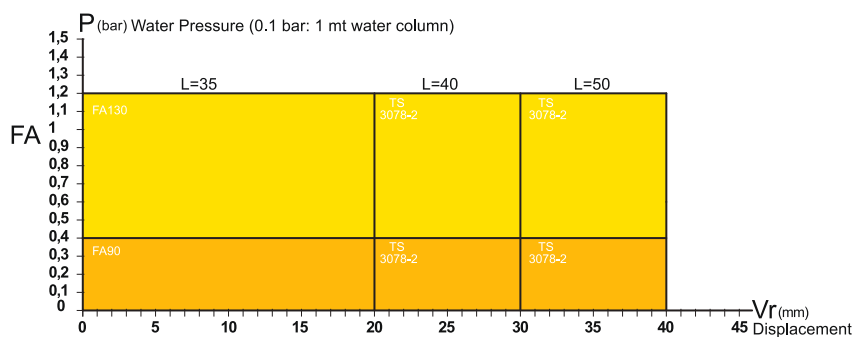

Type FA Waterstop Tape Seal, Nominal Dimensions (mm)

| Product Code | a | c | d | N | e | f | f_1 | g | h | i | k | l |
|--------------|---------|---------|---------|---------|---------|---------|-----------|------------------------------|---------|------------------|---------|---------|
| | Minimum | Minimum | Minimum | Minimum | Minimum | Minimum | Minimum | Minimum | Minimum | Minimum | Minimum | Minimum |
| FA 50-5 | 50 | 5 | 5 | 2 | - | 25 | 20 f-c | 5 $\geq d$ $\geq 0.2f$ | 4 | 11 $\geq h+6$ | 20 | 35 |
| FA 90-5 | 90 | | | 4 | | | | | | | | |
| FA 130-5 | 130 | | | 6 | | | | | | | | |

TS 3078-1 Table 5

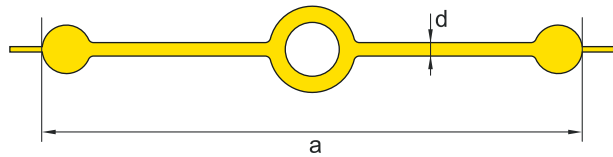
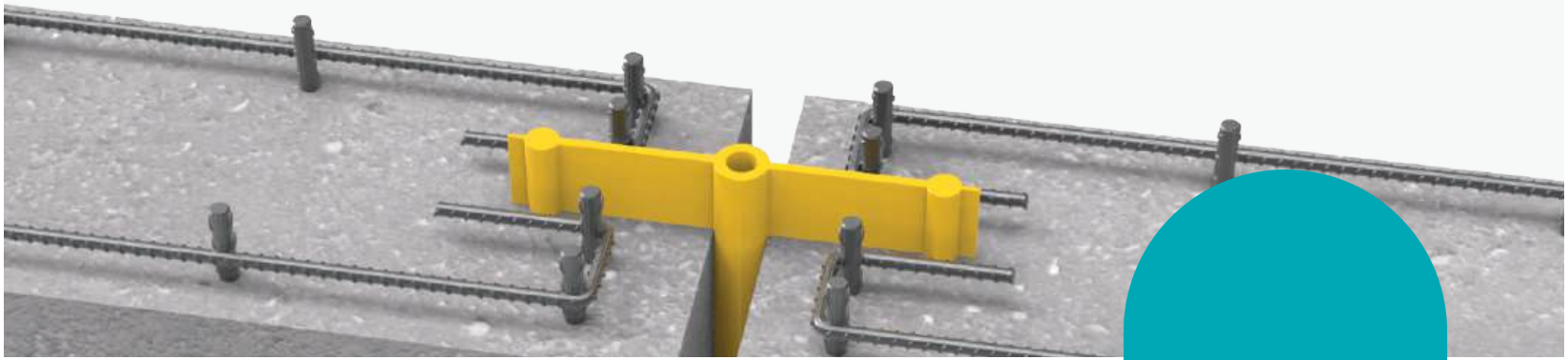

These are waterstop tapes that can be used in low, medium, and high expansion joints, in shear movements, and in structures exposed to high water pressure.



HYDROFLEX TYPE A20/5 WATERSTOP TAPES

High Water
Pressure Resistant
PVC Waterstop Tape

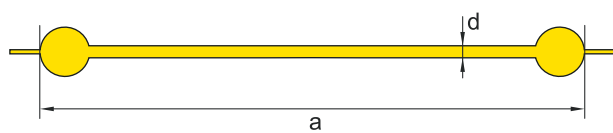
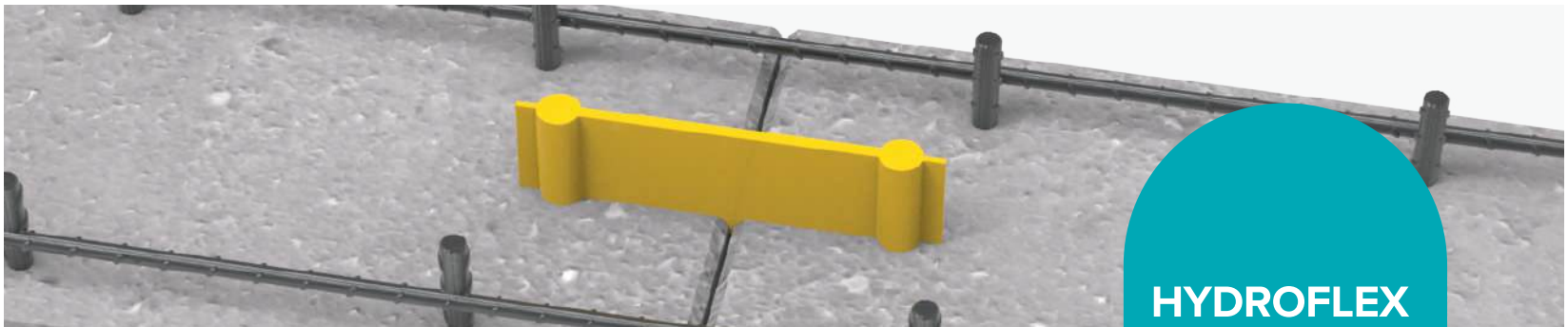

These are waterstop tapes used in full and partial contraction joints under low and high water pressure. The production length is 20 meters.

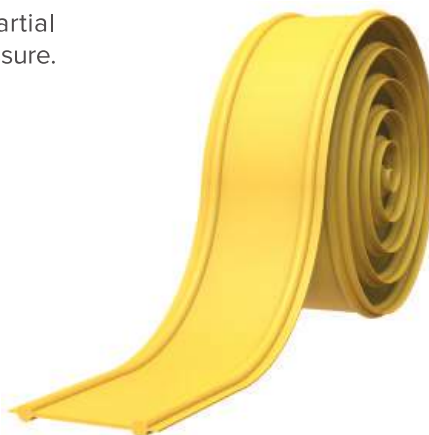

HYDROFLEX TYPE B WATERSTOP TAPES

Professional Solution for
Partial Contraction and
Full Contraction Joints

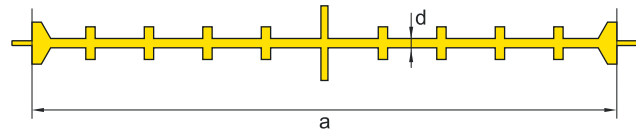
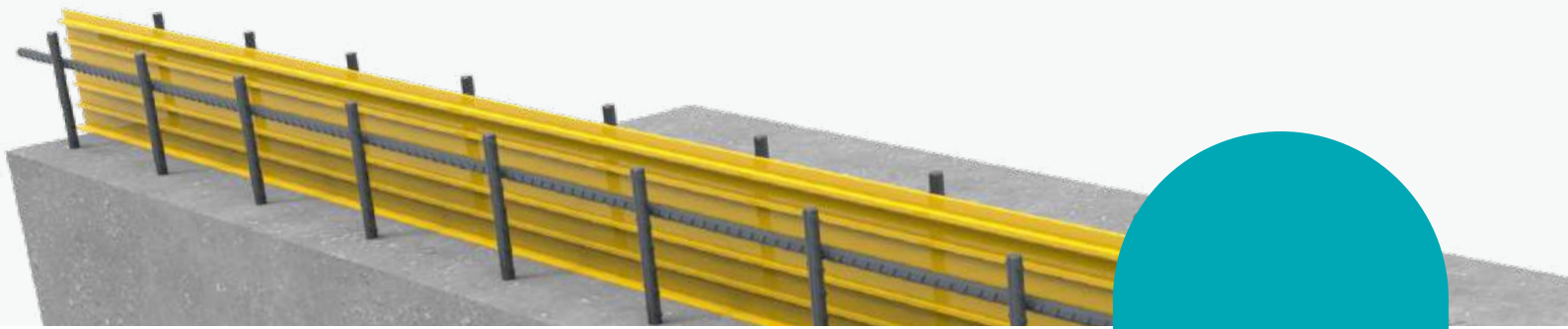

Type I waterstop tapes are used in both full and partial contraction joints and are suitable for structures exposed to both low and high water pressure. They are utilized in joints such as radial-radial, radial-curtain, and curtain curtain intersections, with the tape placed in the middle of the section. These tapes are manufactured in various widths and have lengths of 20 meters.



**HYDROFLEX
TYPE I
WATERSTOP
TAPES**
PVC Waterstop Tape
Resistant to Low and High
Water Pressure

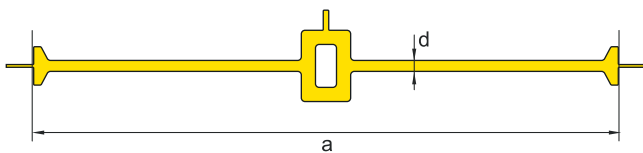

In medium and high expansion joints, they are waterstop strips resistant to shear movement and high pressure. They are available in sizes O 18-3 and O 32-6.



**HYDROFLEX
TYPE O
WATERSTOP
TAPES**
High Performance in
Partial and Full
Contraction Joints

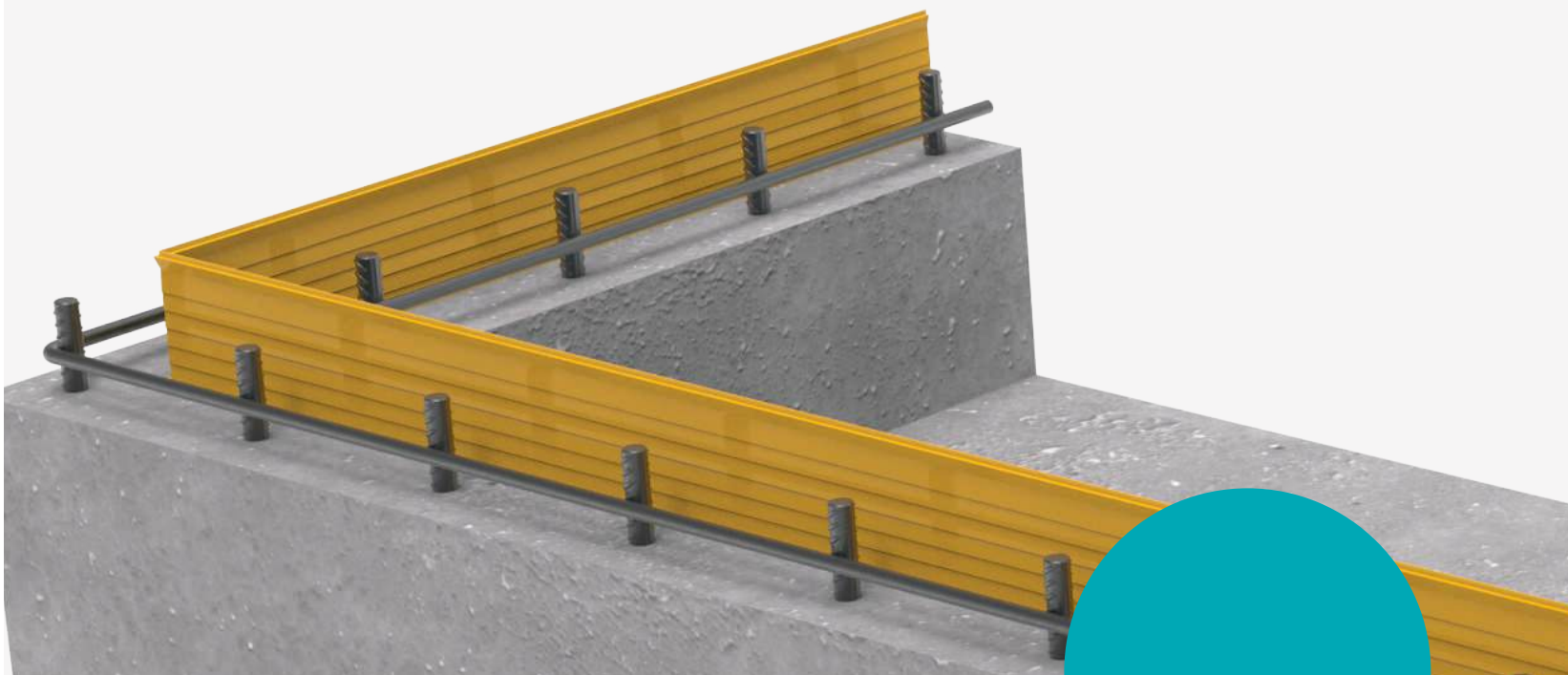

Type AK waterstop tapes are used in both full and partial contraction joints and are preferred in structures with low water pressure due to their economic nature. They are chosen for their cost-effectiveness in buildings with low water pressure. Because their thickness is less compared to other types, they need to be securely attached to prevent folding within the concrete.

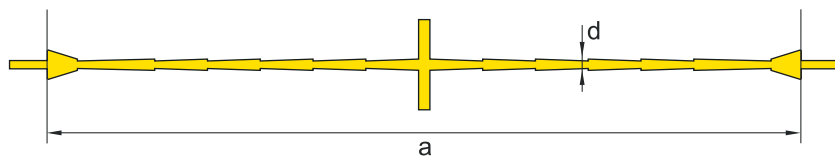

HYDROFLEX TYPE AK WATERSTOP TAPES



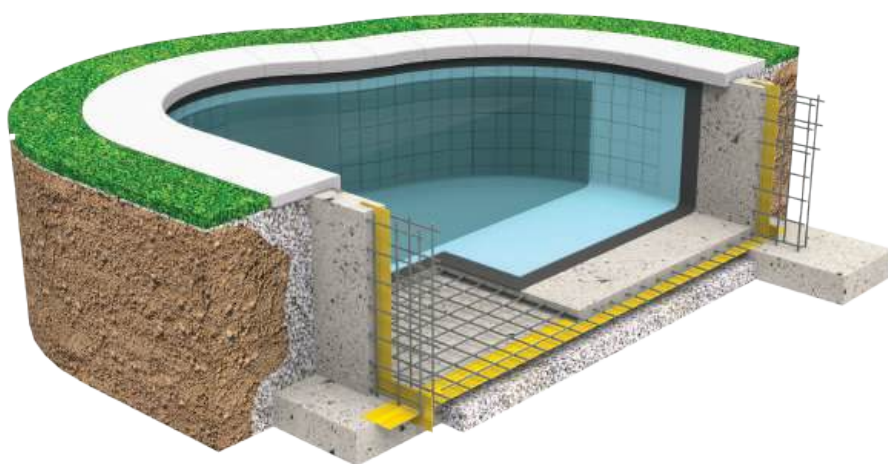







Economical Waterstop
Tapes Resistant to
Low Water Pressure



Packaged Product Images



PVC WATERSTOP TYPES

| TYPE | TECHNICAL DRAWING | WIDTH (cm) | THICKNESS (mm) |
|---------|---|---|----------------|
| A 20-3 |  | 20 | 3 |
| A 24-4 | | 24 | 4 |
| AA 24-4 |  | 24 | 4 |
| D 24-4 |  | 24 | 4 |
| D 32-5 | | 32 | 5 |
| DA 24-4 |  | 24 | 4 |
| DA 32-4 | | 32 | 4 |
| FA 90-5 |  | 9 | 5 |
| AK 20-2 |  | 20 | 2.5 |
| AK 20-3 | | 20 | 3 |
| B 15-5 |  | 15 | 5 |
| B 20-4 | | 20 | 4 |
| B 25-5 | | 25 | 5 |
| I 10-5 |  | 10 | 5 |
| I 20-4 | | 20 | 4 |
| I 20-5 | | 20 | 5 |
| I 25-4 | | 25 | 4 |
| I 25-5 | | 25 | 5 |
| I 32-6 | | 32 | 6 |
| O 18-3 | |  | 18 |
| O 32-6 |  | 32 | 6 |
| A 20-4 |  | 20 | 4 |
| A 20-5 | | 20 | 5 |
| A 25-5 | | 25 | 5 |
| A 25-8 | | 25 | 8 |



HYDROFLEX SODIUM BENTONITE BASED WATER SWELLING TAPE

Easy Application
High Performance

It is a sodium bentonite and butyl rubber based waterstop tape that swells when in contact with water, filling the cracks, pores and capillary spaces in the concrete and makes the concrete waterproof.

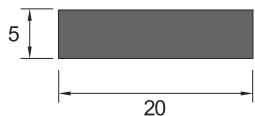

Hydroflex 5x20B

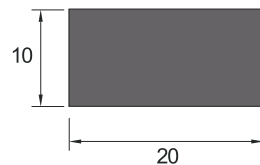

Hydroflex 10x20B

FEATURES AND ADVANTAGES

- It is easy to work with and fast installation can be done.
- Can even easily be applied in excessive reinforcement areas.
- Joining the gap consists of bringing them side by side and pressing them.
- Since it swells in a controlled manner, it does not swell suddenly during concrete pouring.
- It can be used safely as it does not mix with drinking water.
- It is used in pool, foundation, tunnel, subway, retaining wall, garage, curtain concrete, water tank, sewerage, water treatment plant constructions, underground pipe and cable passages, concrete joints, dam, highway, junctions of old and new concrete.





HYDROFLEX TPE BASED WATER SWELLABLE TAPE

High Elongation
Performance
Durable Construction

The TPE-based water-swelling tape is a type of tape with a 350% expansion ratio. It is available in sizes of 5x20 and 10x20, and is produced in 20-meter rolls.

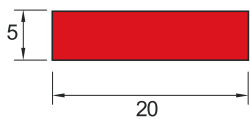

Hydroflex 5x20T

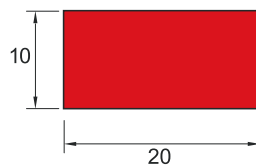

Hydroflex 10x20T

USAGE AREAS

- indoor and outdoor places
- In pools, water tanks, treatment plants
- At foundation - curtain joints, curtain - curtain joints
- In Tunnel Segments
- They are used in partial contraction and full contraction joints in all kinds of reinforced concrete and concrete structures.

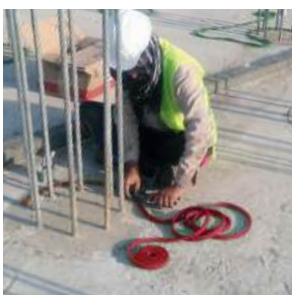



HYDROFLEX TPE BASED WATER SWELLABLE TAPE

Easy and Fast
Application Advantage

HOW DOES IT WORK?

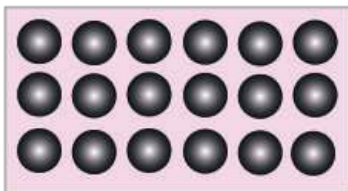

A special additive interacting with water is added to the TPE mixture during production.

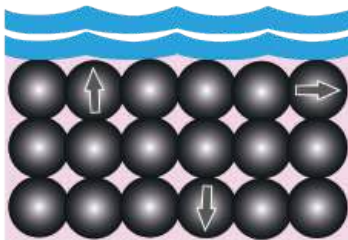

TPE expands uniformly and closes the gaps when the product stays in water or comes into contact with water.

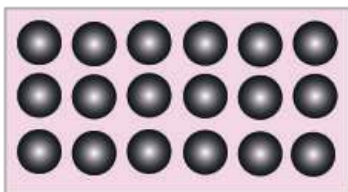

When the water source is withdrawn, the TPE mixture shrinks back to its original size and returns to its original size.

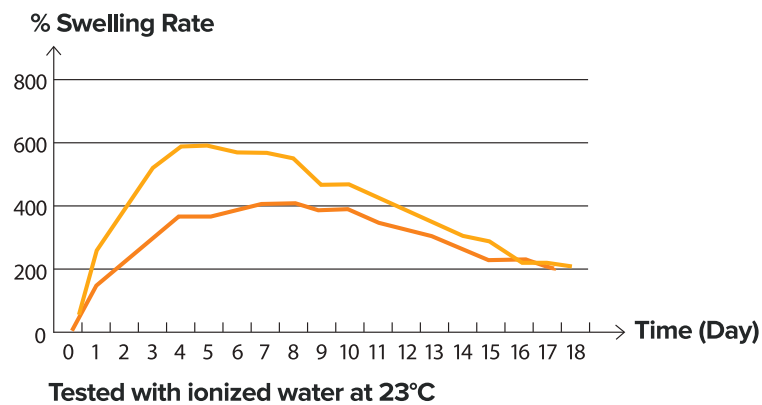



HYDROFLEX TPE EXPANSION JOINT TAPES

High Adhesion Strength
Easy Application

Hydroflex Expansion Joint Tapes are used to provide water insulation in existing or potential joints after concrete casting. HYDROFLEX is a highly elastic expansion joint tape used for the insulation of expansion gaps, thermal expansion joints, and cracks. It is produced in widths of 150 mm - 200 mm - 250 mm - 300 mm - 400 mm - 500 mm - 550 mm, with thicknesses of 1 mm, 1.5 mm, and 2 mm, available in both perforated and non-perforated forms.

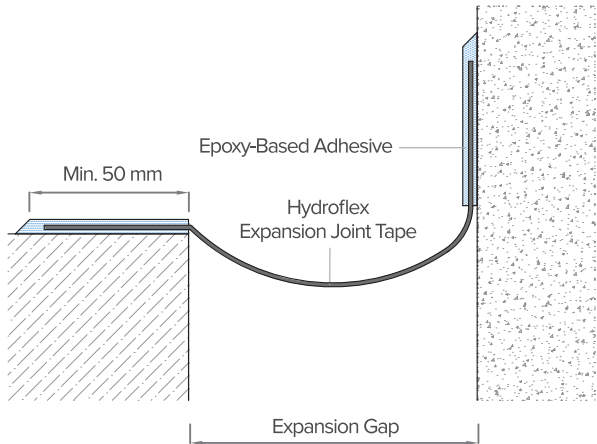
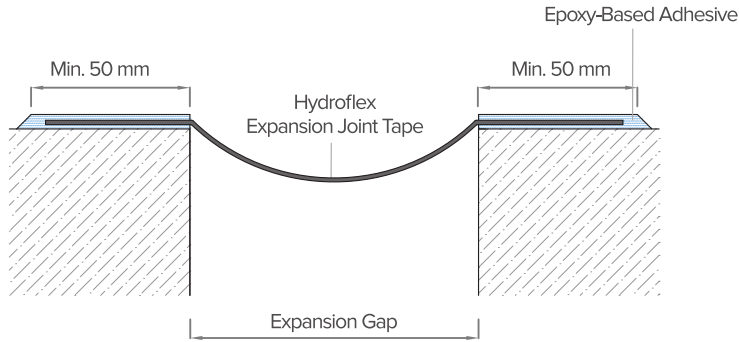

| PRODUCT CODE | WIDTH | THICKNESS | LENGTH |
|---------------|-------|----------------------|--------------|
| HYDROFLEX 150 | 150 | 1 mm & 1,5 mm & 2 mm | 25 mt / roll |
| HYDROFLEX 200 | 200 | 1 mm & 1,5 mm & 2 mm | 25 mt / roll |
| HYDROFLEX 250 | 250 | 1 mm & 1,5 mm & 2 mm | 25 mt / roll |
| HYDROFLEX 300 | 300 | 1 mm & 1,5 mm & 2 mm | 25 mt / roll |
| HYDROFLEX 400 | 400 | 1 mm & 1,5 mm & 2 mm | 25 mt / roll |
| HYDROFLEX 500 | 500 | 1 mm & 1,5 mm & 2 mm | 25 mt / roll |
| HYDROFLEX 550 | 550 | 1 mm & 1,5 mm & 2 mm | 25 mt / roll |



FEATURES AND BENEFITS

- Easy application with epoxy adhesive
- High elasticity, up to 600%
- High adhesive strength
- Resistance to plant roots
- Resilience to ozone, diesel, and oil
- High performance across a wide temperature range of -40 °C to +90 °C
- Capable of bonding with heat

USAGE AREAS

- In all building expansion joints, both horizontally and vertically
- In foundations and underground parts of walls
- Used in structures such as wastewater treatment plants, drinking water facilities, water reservoirs, and pools
- In tunnels and culverts
- Applied in cold joint waterproofing of column-to-wall and wall-to-wall joints

HYDROFLEX TECHNICAL SPECIFICATIONS

| | |
|---------------------------------------|-------------------------------|
| MATERIAL CHEMICAL COMPOSITION | TPE (Thermoplastic Elastomer) |
| COLOUR | Grey |
| HARDNESS LEVEL | 70 |
| SERVICE TEMPERATURE RANGE | -40 °C / +90 °C |
| THERMAL WELDING TEMPERATURE | 270 °C |
| ELONGATION AT BREAK | %600 |
| TEAR STRENGTH | 30N/mm |
| WATER PRESSURE RESISTANT VALUE | > 5 Bar |
| TENSILE STRENGTH AT BREAK | 7.5 Mpa |
| UV RESISTANCE VALUE | > 7500 h |
| BITUMEN RESISTANCE | Good |
| SULFURIC ACID RESISTANCE | Good |
| ALCOHOL RESISTANCE | Good |
| DETERGENT RESISTANCE | Good |

HYDROFLEX 21 EPOXY ADHESIVE

It is an epoxy-based, two-component, repair, anchoring and bonding mortar.

ADHESIVE USAGE AREAS

It is used for bonding dilatation tape.

ADHESIVE FEATURES AND ADVANTAGES

It has high adhesion strength and is resistant to chemicals. It does not contain solvents. It is applied in floor, wall, curtain and terrace expansions. Water and gas proof. Can be applied to damp surfaces. It has a soft consistency and is easy to apply.





HYDROFLEX CHAMFER TAPES

Felt and Mesh
Chamfer Tapes

It is used to prevent cracks in inner and outer corner chamfers and to ensure continuity in sliding-based insulation applications in wet areas and terraces. It is shipped in rolls of 50 meters. Internal and external corners are available.

- The purpose of waterproofing in wet areas, floors and It is to stop the moisture that may occur on the walls and enable it to evaporate.
- Hydroflex Chamfer Tape is used in order to prevent cracks in the inner corners in case of using liquid waterproofing materials in wet areas.
- Liquid waterproof materials, which are normally flexible on flat surfaces, cannot tolerate discontinuity in case of cracks in the inner corners. Generally, these are the points where water seepage happens most commonly.
- These sensitive areas should be isolated with special polyester tapes.
- After the Hydroflex chamfer tape is placed on the insulation adhesive, the top layer of adhesive should be applied again with in a 10 cm area.
- In order to provide a proper isolation, the continuity of the applied tape should be ensured. In addition, physical damage (tearing, impact, etc.) should be avoided while ceramic or other finishing materials are placed in place.

Hydroflex 121
Felt Chamfer Tape

Hydroflex 120
Mesh Chamfer Tape

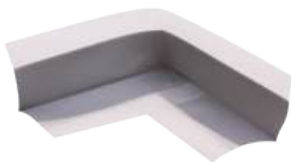

Hydroflex 120 İK
Internal Corner Element



Hydroflex 120 DK
External Corner Element

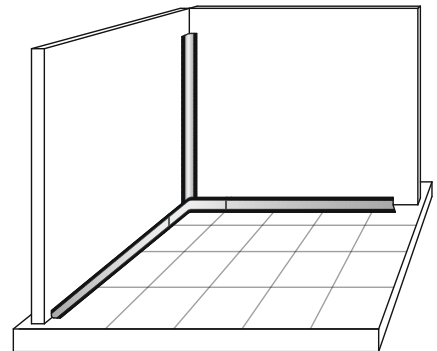



HYDROFLEX 40 FC is a one-component, high-modulus polyurethane sealant that cures on exposure to atmospheric humidity. It possesses excellent adhesion to sheet iron, aluminum, stainless steel, lead, copper, ceramic, wood etc. (40 SHORE / 600 ML SAUSAGE)

FEATURES & BENEFITS

- Fast Curing
- Durable adhesion
- Permanently flexible
- Non-sag consistency - Exceptionally thixotropic
- Non-sticky / does not pick up dirt
- No change in volume
- Easy to gun, can be easily smoothed
- Over-paintable

HYDROFLEX 40 FC POLYURETHANE SEALANT

Fast Curing
Single Component
General Purpose
Construction and
Automotive Sealant



HYDROFLEX 40 MS is a universal grade, general purpose all-weather adhesive sealant based on AST polymer. Combines the properties of both silicone and the polyurethane that makes it an optimum choice for a variety of substrates including: Aluminum, Granite, Ceramics, Marble, Porcelain, Metals, PVC, Glass, Wood, Porous Surfaces (Concrete, Brick, Limestone, etc.). (40 SHORE / 600 ML SAUSAGE)

FEATURES & BENEFITS

- Does not contain solvent, silicone or isocyanate,
- Very Low VOC content,
- No bubble formation, even in wet and humid conditions,
- Very good UV resistance
- Over-paintable with water based paints,
- No shrinkage
- Does not cause oil stains in panels and porous material
- Non-sag, very easy to apply
- No surface tackiness

HYDROFLEX 40 MS POLYMER SEALANT

UV Resistant
Hybrid Polymer Based
High Strength
General Purpose Sealant





It is a product group that is used at the end points of insulation in all kinds of bituminous, pvc, tpo, tpe membrane applications and completes waterproofing. There are surface mounted and flush mounted models as well as wide flashing types are available.

HYDROFLEX INSULATION PRESSURE PROFILE AND FINISH PROFILES

Decorative Appearance

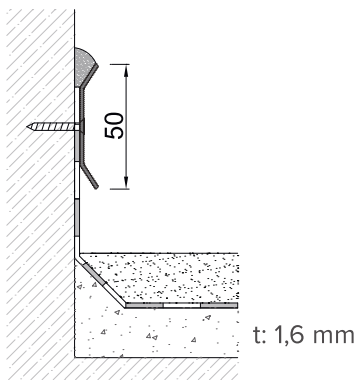

AR2002

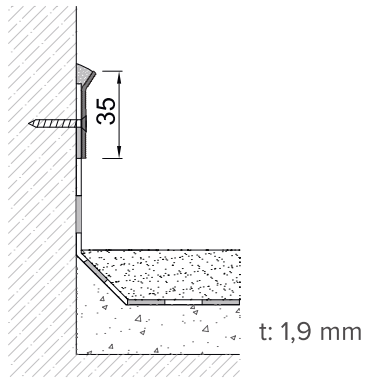

AR2004

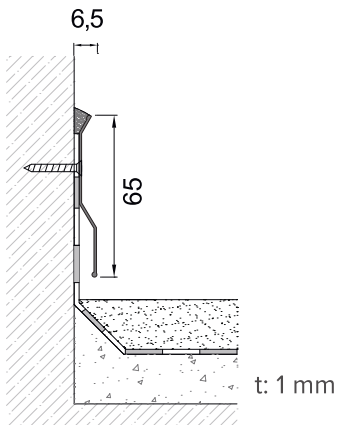

AR2005

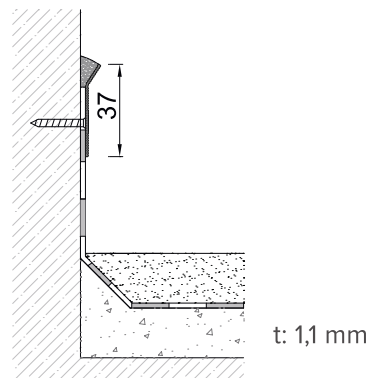

AR2006

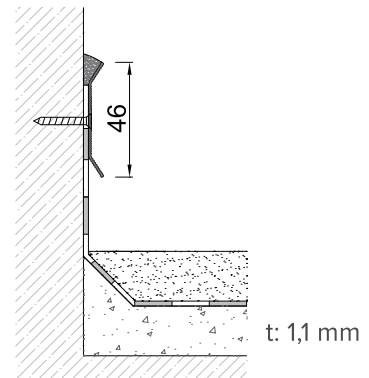

AR2007



**HYDROFLEX
INSULATION
PRESSURE
PROFILE
AND FINISH
PROFILES**
Complements
Waterproofing

AR2009

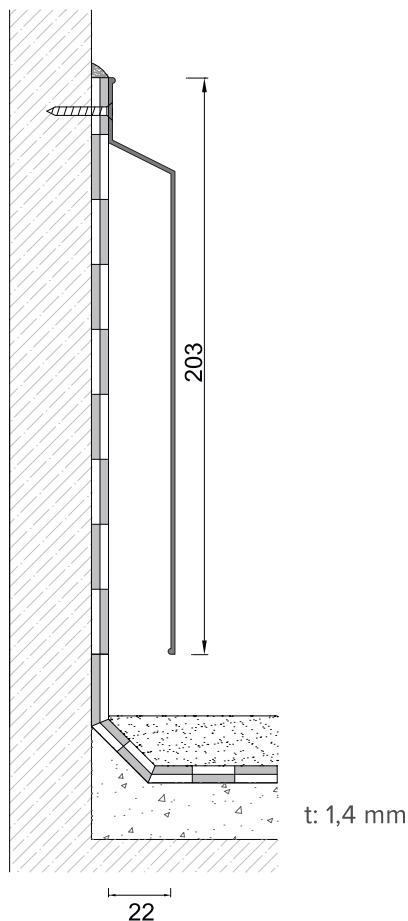

AR2008

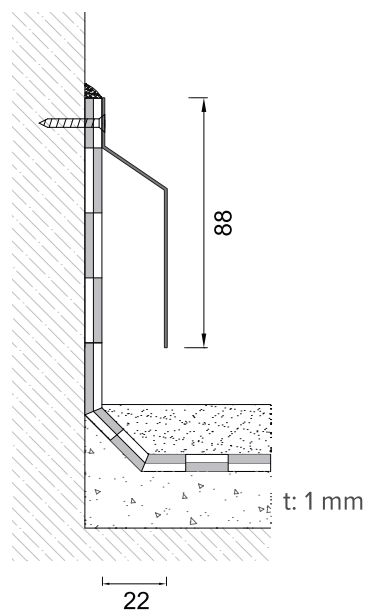

AR2001

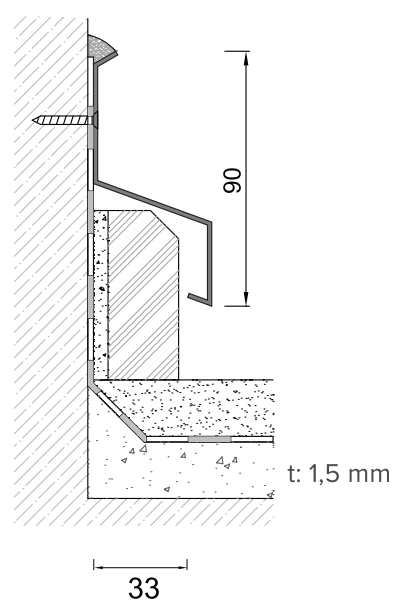

AR2003

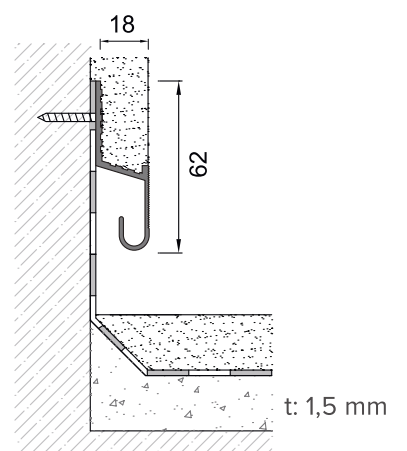



HYDROFLEX BB SERIES

Butyl Tapes

Hydroflex BB Series Butyl tape is a kind of adhesive tape with strong adhesive and excellent sealing effect. It has excellent adhesion to all kinds of material surfaces (color steel plate, steel, waterproof coiled material, cement, wood, PC, PE, PVC, EPDM, CPE materials). Thus, it is also referred to as self adhesive type sealing tape.

TYPICAL USES

Butyl Tape is designed to seal and prevent the entry of dust, air and moisture and assure a weather tight seal in metal building details.

- Metal rib and end joints
- Standing seam roof end laps
- Sealing roof curbs roof jacks and skylights
- Sealing polyethylene sheeting
- Sealing air conditioning equipment
- Window and door flanges

ADVANTAGES

- Excellent for sealing
- Non-staining
- Permanently flexible
- Resistant to ultraviolet and infrared radiations, precipitation, atmospheric hydrocarbon contamination and extremes in temperature

SPECIFICATION

| | |
|-------------------------------|--|
| Colors | Grey |
| Density (gr/cm ³) | 1,5± 0,2 |
| Dimensions: | |
| Width (mm) | 20-30-50-100-200 |
| Thickness (mm) | 1 |
| Roll lengths (meters) | 10 |
| Life Expectancy | In excess of 25 years |
| U.V. Resistance | Excellent |
| Service Temp. Range | -40°C to +93°C |
| Application Temp. Range | -20°C to +49°C |
| Shelf Life | 36 months in ambient conditions (+10° C and +25°C) |
| Joint Movement Range | Up to 15% |





HYDROFLEX BBA SERIES

Aluminium Flashing
Butyl Tape

Hydroflex BBA Series Aluminum butyl tape is self adhesive sealing tape made of a butyl rubber compound, protected by a reinforced aluminium metal film. It is ideal for covering seals of construction and connecting joints in buildings and industry and for sealing both internal and external joints and overlaps (metalwork, container construction, conservatories, air-conditioning and ventilation construction). In addition, when used in the construction of windows and facades, Aluminum butyl tape is ideal for sealing connections and joints (where a gas and diffusionproof seal is necessary).

TYPICAL USES

- Excellent waterproofing, airtight tape for building & construction applications.
- Waterproof applications in roofs, balconies & window areas.
- Excellent permanent repair system for cracked area.
- Used to fix and seal waterproofing sheets.
- It is fit for the waterproofing and sealing for various kinds of roofing engineering, color steel, steel structure, waterproof roll and PC sheet which are exposed to the sunshine.
- Insulation of metal facades and air ducts against water and moisture.

ADVANTAGES

- The butyl adhesive offers excellent high bond strength and long life durability.
- The adhesive forms an immediate bond with no curing time & is chemically inert - (safe to use).
- No pre heating & the adhesive does not leach or stain.
- Good cold temperature bonding .
- Excellent resistant to aging, weathering and UV.
- Non-toxic.
- Very easy to apply (self-adhesive).

SPECIFICATION

| | |
|------------------------------------|--|
| Colors | Tape available in various colours: -Upper side: Aluminium foil -Lower side: Self-adhesive butyl rubber compound protected with a release film, in grey |
| Density (gr/cm³) | 1,5± 0,2 |
| Dimensions: | |
| Width (mm) | 50-100-150-200-250-300 |
| Thickness (mm) | 1 |
| Roll lengths (meters) | 10 |
| Life Expectancy | In excess of 25 years |
| U.V. Resistance | Excellent |
| Service Temp. Range | -40°C to +90°C |
| Application Temp. Range | +5°C to +40°C |
| Shelf Life | 36 months in ambient conditions (+10° C and +25°C) |



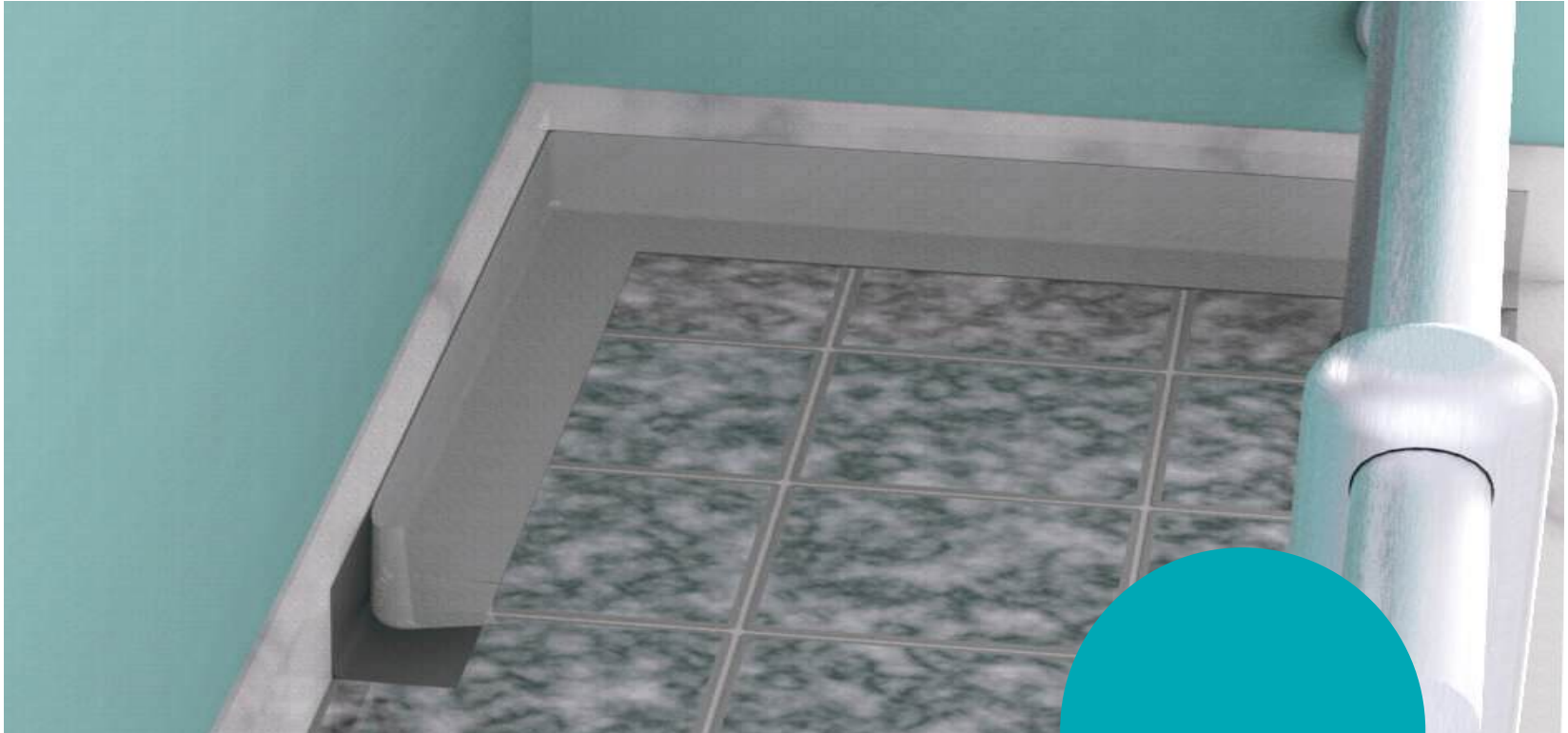

HYDROFLEX BBP SERIES

Polypropylene
Fabric Covered
Butyl Tape

Hydroflex BBP Series Nonwoven Butyl Tape is a single sided Butyl Adhesive tape with a non woven polyester fabric exterior layer and is coated one side with a high tack butyl adhesive. The adhesive layer is protected by a peelable paper release liner. The fleece fabric surface of the sealing tape allows for painting, plastering and therefore completely covered installation.

TYPICAL USES

- Excellent waterproofing, airtight tape for building & construction applications.
- Waterproof applications in wetrooms, balconies & window areas.
- It has been used under tiles in wetroom areas
- Excellent permanent repair system for cracked concrete and plaster areas.
- Used as a secondary waterproof & insulation sealing system with in the building structure.
- Used to fix and seal waterproofing sheets.

ADVANTAGES

- The butyl adhesive offers excellent high bond strength and long life durability.
- The adhesive forms an immediate bond with no curing time & is chemically inert - (safe to use).
- Easily applied, no pre heating & the adhesive does not leach or stain.
- Good cold temperature bonding.

SPECIFICATION

| | |
|-------------------------------|---|
| Colors | Grey |
| Density (gr/cm ³) | 1,5± 0,2 |
| Dimensions: | |
| Width (mm) | 100-150-200-250-300 |
| Thickness (mm) | 1 |
| Roll lengths (meters) | 10 |
| Life Expectancy | In excess of 25 years |
| U.V. Resistance | Excellent |
| Service Temp. Range | -40°C to +90°C |
| Application Temp. Range | +5°C to +40°C |
| Shelf Life | 36 months in ambient conditions (+10°C and +25°C) |
| Elongation | Up to 35% |





we build solutions



we
build
solutions



www.arfen.com - www.arfen.eu



ARFEN CONSTRUCTION MATERIALS COMPANY

Headquarter: Atatürk San. Bölgesi Ömerli Mah. Hakkı İleri Cad.
Gülce Sk. No:22 Arnavutköy - İSTANBUL / Turkey
Tel: +90 212 485 16 15 - Fax: +90 212 771 25 79 - www.arfen.com

ARFEN EUROPE SRL

Bucharest, Romania - www.arfen.eu

ARFEN USA INC

Florida / USA - www.arfenusa.com

ARFEN ALUMINIUM COMPANY

Tekirdağ / Turkey - www.arfenaluminyum.com.tr

ARFEN BUILDING AND BRIDGE TECHNOLOGY

Kocaeli / Turkey - www.arfen.com.tr

detaylı bilgi için

